

8 7 6 5 4 3 2 1

| REVISIONS | | | |
|-----------|-------------|------|----------|
| REV. | DESCRIPTION | DATE | APPROVED |

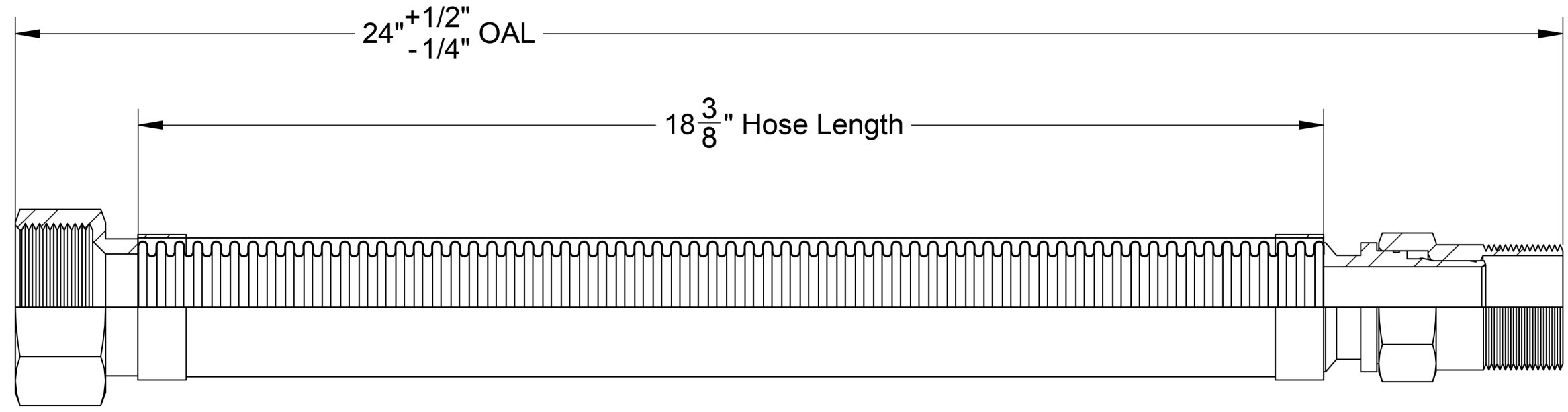

D
C
B
A

D
C
B
A

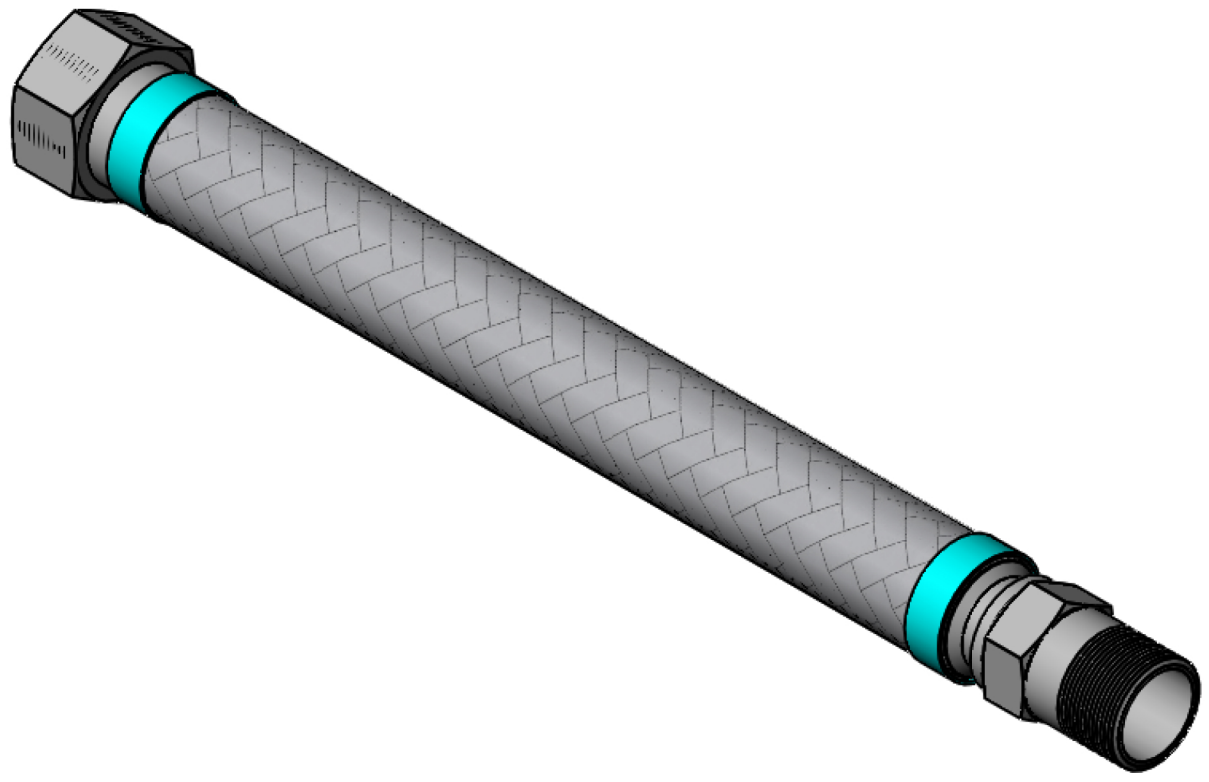

| ITEM # | QTY. | PART NUMBER | DESCRIPTION | MATERIAL | WEIGHT |
|--------|------|------------------|--|-----------------|--------|
| 1 | 1 | HOSE | 300 Series Stainless HYDROFORMED Corrugated Hose | Stainless Steel | 0.79 |
| 2 | 1 | BRAID | 300 Series Stainless Steel | Stainless Steel | 0.07 |
| 3 | 2 | BRAID COLLAR | 0.05" Thick | Stainless Steel | 0.07 |
| 4 | 1 | 2" FEMALE | 2" Female, 2"x11-1/2" Thread, 2.38" Hex | Carbon Steel | 0.76 |
| 5 | 1 | 1.5" MALE SWIVEL | 1.5" Male Swivel, 1-1/2"x11-1/2" Thread, 1.94" Hex | Carbon Steel | 1.40 |

| | | | |
|---|---|--|-----------------------------------|
|  | HOSE MASTER Inc. 1233 East 222nd Street • Cleveland, Ohio 44117 (800) 221-2319 • Fax: (216) 481-7557 • www.hosemaster.com Locations: Cleveland • Houston | | Registered to: ISO 9001 : 2000 |
| |  | | |

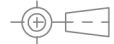
| | | |
|---|---|--|
| Projection: | Customer: Hose Master Inc. | Prepared By: kannk |
|  | Reference: Fire-Shield - 2" Female x 1.5" Male Swivel x 24" OAL | CALC. WEIGHT: 3 lbs. Date: 9/24/2009 |

Description: **1.5" ID x 24" OAL 300 Series Stainless HYDROFORMED Corrugated Hose covered by 300 Series Stainless Braid. UL Approved 2" Female Connector x 1.5" Male Swivel Connector**

| | | | | | |
|------------|--------------------|-------|---|-------|--------|
| Drawing #: | FSFS0150x24 | Rev.: | - | SHEET | 1 OF 1 |
|------------|--------------------|-------|---|-------|--------|



8 7 6 5 4 3 2 1